

# PRODUCT DIAGRAM - ELITE SYSTEM

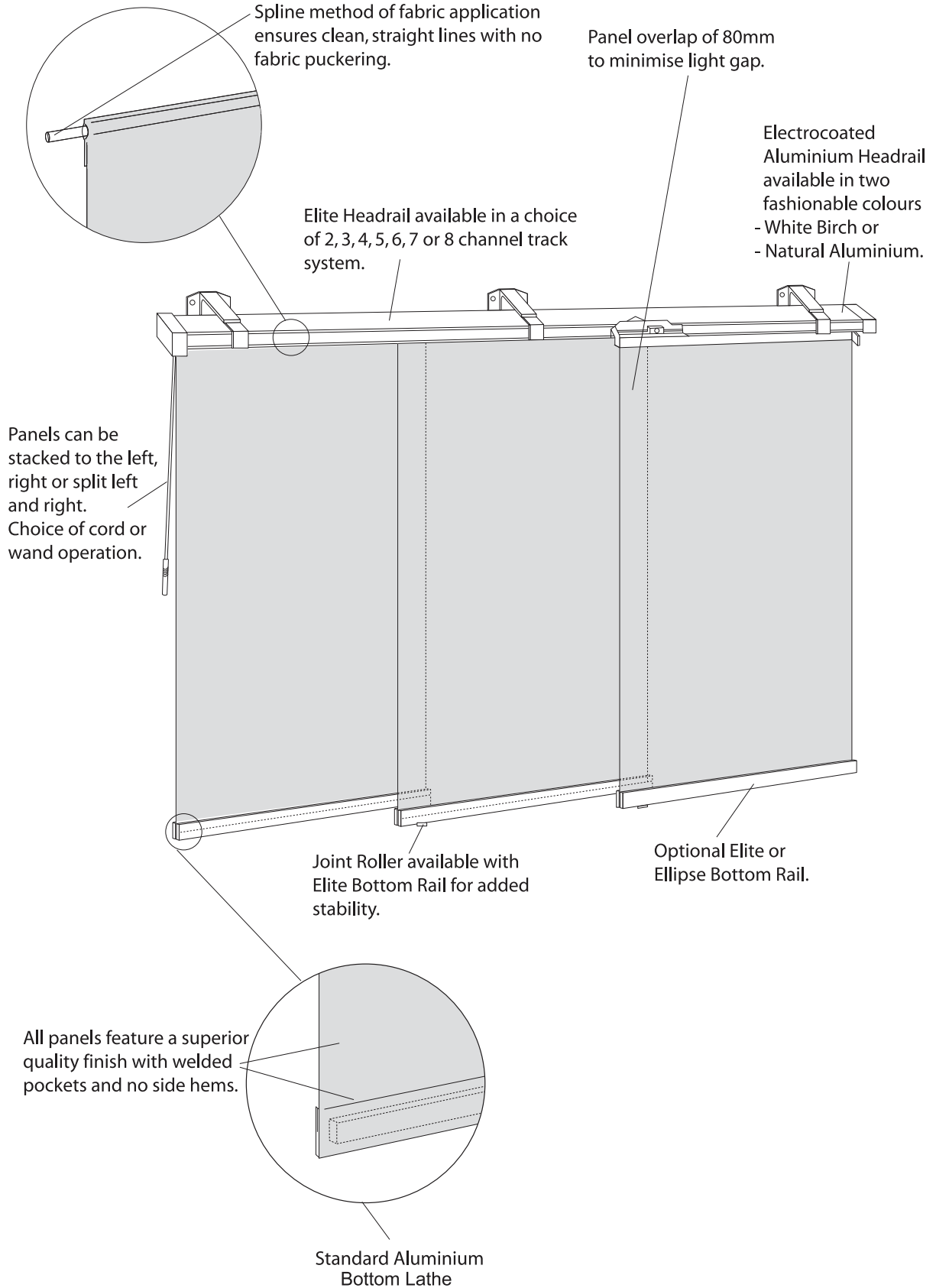

## CHANNEL DIMENSIONS

2 Channels	45mm wide x 28mm high
3 Channels	65mm wide x 28mm high
4 Channels	88mm wide x 28mm high
5 Channels	111mm wide x 28mm high
6 Channels	132mm wide x 28mm high
7 Channels	155mm wide x 28mm high
8 Channels	178mm wide x 28mm high

# MEASURING DIAGRAM

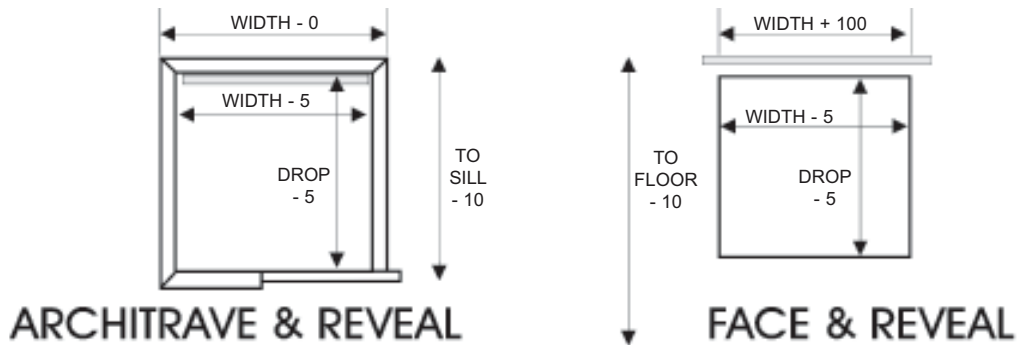

## FACTORY DEDUCTIONS

### BLIND WIDTH REVEAL

$$\text{Blind width (W)} = \text{measured width} - 5\text{mm}$$

### BLIND HEIGHT

$$\text{Blind height (H)} = \text{measured height} - 5\text{mm (sill) max.}$$

$$\text{Blind height (H)} = \text{measured height} - 10\text{mm (floor) max.}$$

**NOTE:** Panel Glide Elite System blinds with 5 or more panels cannot be installed in face.

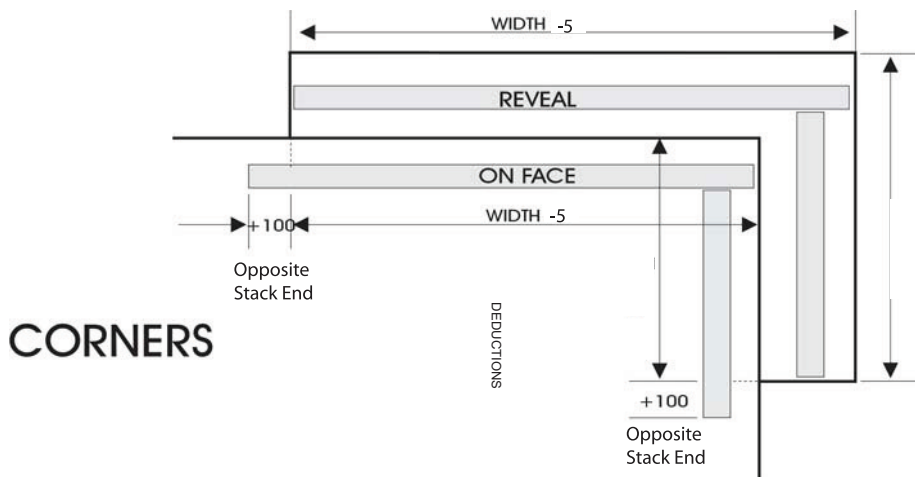

**NOTE:** There is an acceptable 5mm tolerance in the drop between panels

# INSTALLATION INSTRUCTIONS

1. Install the rail. The 2, 3, and 4 track systems each feature one rail. The 5, 6, 7 and 8 track systems each feature two rails. When two rails are used, be sure to install them parallel. Make sure that the side of the rail containing the stop is placed at the front.

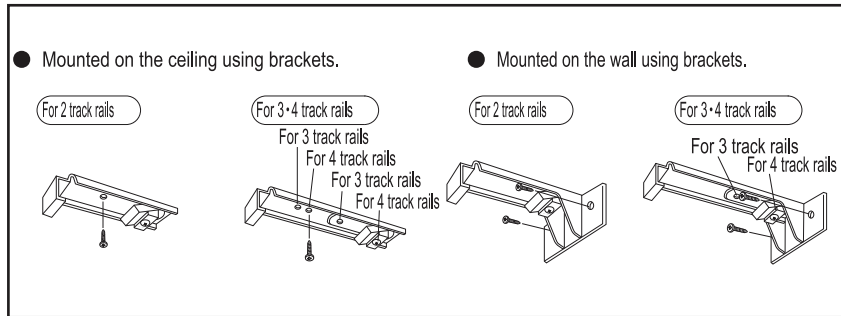
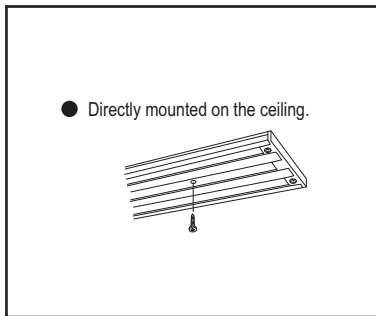

\* The bracket for the 3 and 4 panel track is set for 4 channels. When installing a 3 track system, reposition the plastic claws for the 3 channels.

## BRACKET POSITION:

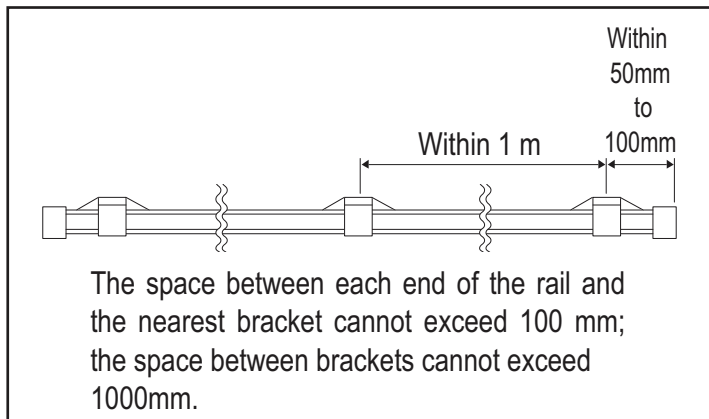

2. Starting from the rear most panel, insert a Spline into the channel at the top of the fabric panel and insert it into the Carrier Bar. Make sure that the panel is not upside down or reversed. Do the same with the remaining screen panels.

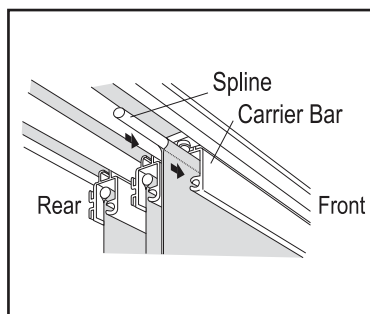

# INSTALLATION INSTRUCTIONS

3. Attach the caps to all of the Carrier Bars. The locking screw is to be inserted into the lower hole in each Carrier Bar Cap.

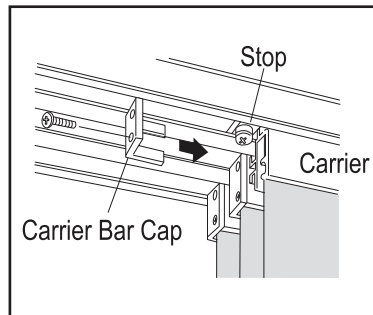

## 4. IF ELITE BOTTOM RAIL:

Insert the spline into the channel at the bottom of the panel and insert it into the bottom rail. Do the same with the remaining panels.

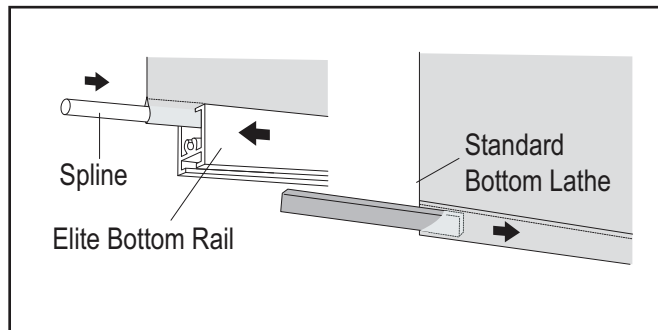

5 Attach the joint roller to the bottom rail in the order shown below.

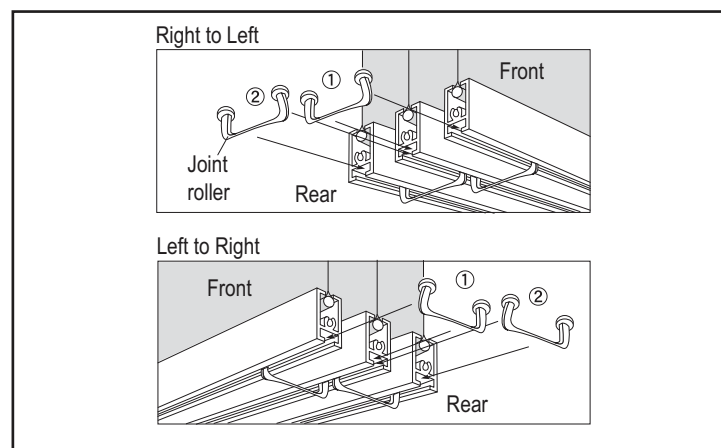

# INSTALLATION INSTRUCTIONS

6. Attach the Elite Bottom Rail Cap to all the Bottom Rails.

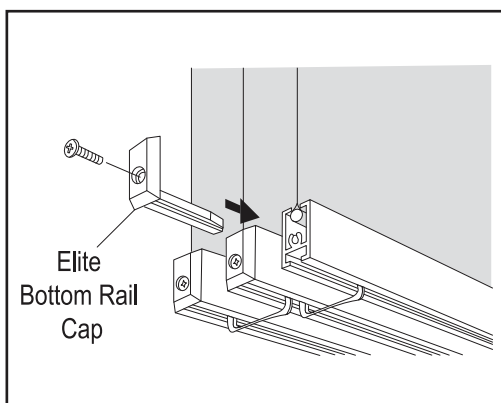

7. In case of a wand-operated screen, hang the wand on the wand hook.

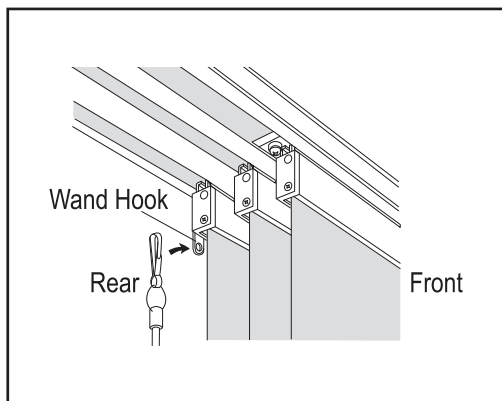

## CHILD SAFETY (CORD OPERATED BLINDS)

Blind cords can pose a potential safety risk, particularly to young children. To reduce the possibility of such an accident, all cords must be kept out of the reach of children, including infants. A cord tensioning device is an effective way to implement this essential precaution.

After the blind has been securely mounted to the window, mount the cord tensioner to the window opening (inside mount) or to the wall (outside mount). Determine the correct mounting option as shown below.

Take care to ensure that the cord does not rub on the fabric.

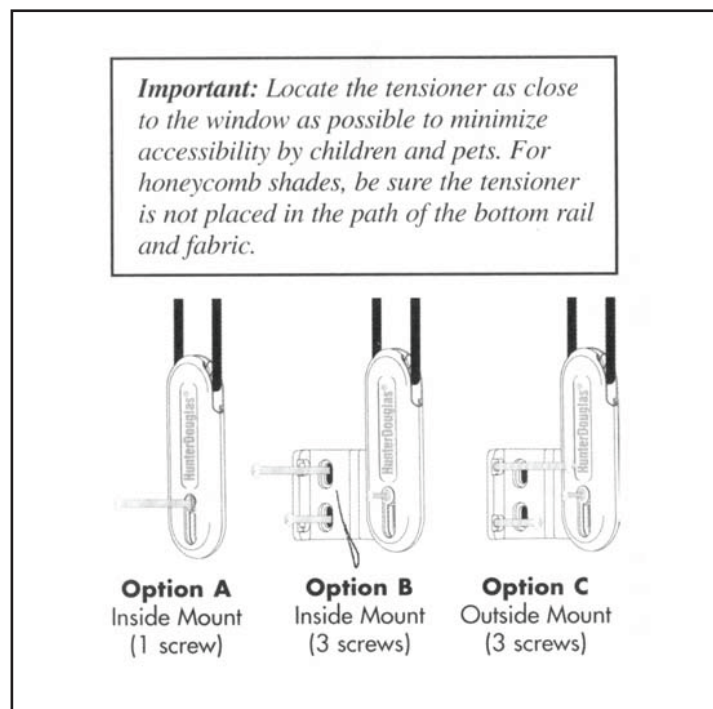

## OPERATION / CARE & CLEANING

Opening and Closing the blind:

Cord Operation - to draw the blind across gently pull down on the front cord attached to the control end of the headrail. To re-open the blind pull down on the rear cord.

Wand Operation - to open and close the blind pull the wand attached to the top of the rear panel.

General Care - dusting with a feather duster is all that is required to keep your Panel Glides looking good.

Stains - for the removal of dirt and grime, simply wipe fabric panels with a sponge soaked in lukewarm water. If marks are still visible add a little mild detergent. Then dry gently with a clean cloth.